



AP[®] Physics C: Mechanics Practice Exam

From the 2013 Administration

This Practice Exam is provided by the College Board for AP Exam preparation. Teachers are permitted to download the materials and make copies to use with their students in a classroom setting only. To maintain the security of this exam, teachers should collect all materials after their administration and keep them in a secure location.

Exams may **not** be posted on school or personal websites, nor electronically redistributed for any reason. Further distribution of these materials outside of the secure College Board site disadvantages teachers who rely on uncirculated questions for classroom testing. Any additional distribution is in violation of the College Board's copyright policies and may result in the termination of Practice Exam access for your school as well as the removal of access to other online services such as the AP Teacher Community and Online Score Reports.

Contents

Exam Instructions

Student Answer Sheet for the Multiple-Choice Section

Section I: Multiple-Choice Questions

Section II: Free-Response Questions

Multiple-Choice Answer Key

Free-Response Scoring Guidelines

Scoring Worksheet

Note: This publication shows the page numbers that appeared in the *2012–13 AP Exam Instructions* book and in the actual exam. This publication was not repaginated to begin with page 1.

Exam Instructions

The following contains instructions taken from the *2012–13 AP Exam Instructions* book.

AP[®] Physics C: Mechanics Exam

Regularly Scheduled Exam Date: Monday afternoon, May 13, 2013

Late-Testing Exam Date: Friday afternoon, May 24, 2013

Section I: At a Glance

Total Time:

45 minutes

Number of Questions:

35

Percent of Total Score:

50%

Writing Instrument:

Pencil required

Electronic Device:

None allowed

Section II: At a Glance

Total Time:

45 minutes

Number of Questions:

3

Percent of Total Score:

50%

Writing Instrument:

Either pencil or pen with black or dark blue ink

Electronic Device:

Calculator allowed

Weight:

The questions are weighted equally.

Section I: Multiple Choice Booklet Instructions

Section I of this exam contains 35 multiple-choice questions. For these questions, fill in only the circles for numbers 1 through 35 on your answer sheet. A table of information that may be helpful is in the booklet. Rulers and straightedges may be used in this section.

Indicate all of your answers to the multiple-choice questions on the answer sheet. No credit will be given for anything written in this exam booklet, but you may use the booklet for notes or scratch work. After you have decided which of the suggested answers is best, completely fill in the corresponding circle on the answer sheet. Give only one answer to each question. If you change an answer, be sure that the previous mark is erased completely.

Use your time effectively, working as quickly as you can without losing accuracy. Do not spend too much time on any one question. Go on to other questions and come back to the ones you have not answered if you have time. It is not expected that everyone will know the answers to all of the multiple-choice questions.

Your total score on the multiple-choice section is based only on the number of questions answered correctly. Points are not deducted for incorrect answers or unanswered questions.

Section II: Free Response Booklet Instructions

The questions for Section II are printed in this booklet. You may use any blank space in the booklet for scratch work, but you must write your answers in the spaces provided for each answer. A table of information and lists of equations that may be helpful are in the booklet. Calculators, rulers, and straightedges may be used in this section.

All final numerical answers should include appropriate units. Credit for your work depends on demonstrating that you know which physical principles would be appropriate to apply in a particular situation. Therefore, you should show your work for each part in the space provided after that part. If you need more space, be sure to clearly indicate where you continue your work. Credit will be awarded only for work that is clearly designated as the solution to a specific part of a question. Credit also depends on the quality of your solutions and explanations, so you should show your work.

Write clearly and legibly. Cross out any errors you make; erased or crossed-out work will not be scored. You may lose credit for incorrect work that is not crossed out.

Manage your time carefully. You may proceed freely from one question to the next. You may review your responses if you finish before the end of the exam is announced.

What Proctors Need to Bring to This Exam

- Exam packets
- Answer sheets
- AP Student Packs
- *2012-13 AP Coordinator’s Manual*
- This book — *AP Exam Instructions*
- School Code and Home-School/Self-Study Codes
- Extra calculators
- Extra rulers or straightedges
- Pencil sharpener
- Extra No. 2 pencils with erasers
- Extra pens with black or dark blue ink
- Extra paper
- Stapler
- Watch
- Signs for the door to the testing room
 - “Exam in Progress”
 - “Cell phones are prohibited in the testing room”

Students are permitted to use four-function, scientific, or graphing calculators to answer the questions in Section II of the AP Physics C: Mechanics Exam. Students are not allowed to use calculators in Section I. Before starting the exam administration, make sure each student has an appropriate calculator, and any student with a graphing calculator has a model from the approved list on page 42 of the *2012-13 AP Coordinator’s Manual*. See pages 39–42 of the *2012-13 AP Coordinator’s Manual* for more information. If a student does not have an appropriate calculator or has a graphing calculator not on the approved list, you may provide one from your supply. If the student does not want to use the calculator you provide or does not want to use a calculator at all, he or she must hand copy, date, and sign the release statement on page 40 of the *2012-13 AP Coordinator’s Manual*.

During the administration of Section II, students may have no more than two calculators on their desks. Calculators may not be shared. Calculator memories do not need to be cleared before or after the exam. Students with Hewlett-Packard 48–50 Series and Casio FX-9860 graphing calculators may use cards designed for use with these calculators. Proctors should make sure infrared ports (Hewlett-Packard) are not facing each other. **Since graphing calculators can be used to store data, including text, proctors should monitor that students are using their calculators appropriately. Attempts by students to use the calculator to remove exam questions and/or answers from the room may result in the cancellation of AP Exam scores.**

Rulers and straightedges may be used for the entire exam.

Students may take both Physics C exams, Mechanics only, or Electricity and Magnetism only. The Mechanics exam is administered first, after which students taking both exams are given a break. Then the Electricity and Magnetism exam is administered. Prior to testing day, determine which exams students are taking. Those taking both Physics C exams and those taking Physics C: Mechanics only should report for the 12 noon start time (11 a.m. in Alaska). Those taking Electricity and Magnetism only should report to the testing room after the break (approximately 2 p.m., 1 p.m. in Alaska). If all students are taking Electricity and Magnetism only, you must not begin the exam before 2 p.m.

The two exams are in separate exam packets, and require separate answer sheets. At the beginning of the session, you will distribute **only** the packets and answer sheets for Mechanics. The materials for Electricity and Magnetism will be distributed after the break.

SECTION I: Multiple Choice

- **Do not begin the exam instructions below until you have completed the appropriate**
- **General Instructions for your group.**

This exam includes survey questions. The time allowed for the survey questions is in addition to the actual test-taking time.

Make sure that you begin the exam at the designated time.

If you are giving the regularly scheduled exam, say:

It is Monday afternoon, May 13, and you will be taking the AP Physics C: Mechanics Exam.

If you are giving the alternate exam for late testing, say:

It is Friday afternoon, May 24, and you will be taking the AP Physics C: Mechanics Exam.

In a moment, you will open the packet that contains your exam materials. By opening this packet, you agree to all of the AP Program’s policies and procedures outlined in the *2012-13 Bulletin for AP Students and Parents*. You may now remove the shrinkwrap from your exam packet and take out the Section I booklet, but do not open the booklet or the shrinkwrapped Section II materials. Put the white seals aside. . . .

Carefully remove the AP Exam label found near the top left of your exam booklet cover. Now place it on page 1 of your answer sheet on the dark blue box near the top right-hand corner that reads “AP Exam Label.”

If students accidentally place the exam label in the space for the number label or vice versa, advise them to leave the labels in place. They should not try to remove the label; their exam will be processed correctly.

Read the statements on the front cover of Section I and look up when you have finished. . . .

Sign your name and write today’s date. Look up when you have finished. . . .

Now print your full legal name where indicated. Are there any questions? . . .

Turn to the back cover and read it completely. Look up when you have finished. . . .

Are there any questions? . . .

Section I is the multiple-choice portion of the exam. You may never discuss these specific multiple-choice questions at any time in any form with anyone, including your teacher and other students. If you disclose these questions through any means, your AP Exam score will be canceled. Are there any questions? . . .

You must complete the answer sheet using a No. 2 pencil only. Mark all of your responses beginning on page 2 of your answer sheet, one response per question. Completely fill in the circles. If you need to erase, do so carefully and completely. No credit will be given for anything written in the exam booklet. Scratch paper is not allowed, but you may use the margins or any blank space in the exam booklet for scratch work. Rulers and straightedges may be used for the entire exam, but calculators are not allowed for Section I. Please put all of your calculators under your chair. Are there any questions? . . .

You have 45 minutes for this section. Open your Section I booklet and begin.



Note Start Time here _____. Note Stop Time here _____. Check that students are marking their answers in pencil on their answer sheets, and that they are not looking at their shrinkwrapped Section II booklets. After 45 minutes, say:

Stop working and turn to the last page in your booklet. . . .

You have 2 minutes to answer Questions 101–106. These are survey questions and will not affect your score. You may not go back to work on any of the exam questions. You may now begin.

To help you and your proctors make sure students are not working on the exam questions, the two pages with the survey questions are identified with a large S on the upper corner of each page. Give students 2 minutes to answer the survey questions. Then say:

Close your booklet and put your answer sheet on your desk, face up. Make sure you have your AP number label and an AP Exam label on page 1 of your answer sheet. I will now collect your answer sheet.

Collect an answer sheet from each student. Check that each answer sheet has an AP number label and an AP Exam label. Then say:

Now you must seal your exam booklet. Remove the white seals from the backing and press one on each area of your exam booklet cover marked “PLACE SEAL HERE.” Fold each seal over the back cover. When you have finished, place the booklet on your desk, face up. I will now collect your Section I booklet. . . .

SECTION II: Free Response

Check that each student has signed the front cover of the sealed Section I booklet. When all Section I materials have been collected and accounted for, say:

May I have everyone’s attention? Place your Student Pack on your desk. . . .

You may now remove the shrinkwrap from the Section II packet, but do not open the exam booklet until you are told to do so. . . .

Read the bulleted statements on the front cover of the exam booklet. Look up when you have finished. . . .

Now place an AP number label on the shaded box. If you don’t have any AP number labels, write your AP number in the box. Look up when you have finished. . . .

Read the last statement. . . .

Using your pen, print the first, middle and last initials of your legal name in the boxes and print today's date where indicated. This constitutes your signature and your agreement to the statements on the front cover. . . .

Turn to the back cover and complete Item 1 under "Important Identification Information." Print the first two letters of your last name and the first letter of your first name in the boxes. Look up when you have finished. . . .

In Item 2, print your date of birth in the boxes. . . .

In Item 3, write the school code you printed on the front of your Student Pack in the boxes. . . .

Read Item 4. . . .

Are there any questions? . . .

I need to collect the Student Pack from anyone who will be taking another AP Exam. Keep it, however, if you will be taking the Physics C: Electricity and Magnetism exam this afternoon. If you have no other AP Exams to take, place your Student Pack under your chair now. . . .

While Student Packs are being collected, read the information on the back cover of the exam booklet. Do not open the booklet until you are told to do so. Look up when you have finished. . . .

Collect the Student Packs. Then say:

Are there any questions? . . .

Calculators may be used for Section II. You may get your calculators from under your chair and place them on your desk. . . .

You have 45 minutes to complete Section II. You are responsible for pacing yourself, and may proceed freely from one question to the next. You must write your answers in the exam booklet using a pen or a No. 2 pencil. If you use a pencil, be sure that your writing is dark enough to be easily read. If you need more paper during the exam, raise your hand. At the top of each extra piece of paper you use, be sure to write only your AP number and the number of the question you are working on. Do not write your name. Are there any questions? . . .

You may begin.



Note Start Time here _____. Note Stop Time here _____. Check that students are writing their answers in their exam booklets. You should also make sure that Hewlett-Packard calculators' infrared ports are not facing each other and that students are not sharing calculators. After 35 minutes, say:

There are 10 minutes remaining.

After 10 minutes, say:

Stop working and close your exam booklet. Place it on your desk, face up. . . .

If any students used extra paper for the free-response section, have those students staple the extra sheet/s to the first page corresponding to that question in their exam booklets. Then say:

Remain in your seat, without talking, while the exam materials are collected. . . .

Collect a Section II booklet from each student. Check for the following:

- Exam booklet front cover: The student placed an AP number label on the shaded box, and printed his or her initials and today's date.
- Exam booklet back cover: The student completed the "Important Identification Information" area.

When all exam materials have been collected and accounted for, return to students who are taking Mechanics only any electronic devices you may have collected before the start of the exam.

If you are giving the regularly scheduled exam, say:

You may not discuss these specific free-response questions with anyone unless they are released on the College Board website in about two days. Your AP score results will be delivered online in July.

If you are giving the alternate exam for late testing, say:

None of the questions in this exam may ever be discussed or shared in any way at any time. Your AP score results will be delivered online in July.

If any students completed the AP number card at the beginning of this exam, and are about to be dismissed, say:

Please remember to take your AP number card with you. You will need the information on this card to view your scores and order AP score reporting services online.

If no students are taking Physics C: Electricity and Magnetism, say:

You are now dismissed.

If some students are taking Physics C: Electricity and Magnetism, say:

Those of you taking Mechanics only are now dismissed.

The students taking the Electricity and Magnetism exam now get a 10-minute break. Remember that the Electricity and Magnetism exam cannot begin before 2 p.m., but should start before 3 p.m. After the students taking Mechanics only have left, say:

If you will also be taking the Physics C: Electricity and Magnetism exam, please listen carefully to these instructions before we take a 10-minute break. Please put all of your calculators under your chair. Your calculators and everything you placed under your chair at the beginning of the exam must stay there. You are not allowed to consult teachers, other students, or textbooks about the exam during the break. You may not make phone calls, send text messages, check email, use a social networking site, or access any electronic or communication device. If you do not follow these rules, your score could be canceled. Are there any questions? . . .



You may begin your break. Testing will resume at _____.

If you will be administering Physics C: Electricity and Magnetism exam at 2 p.m., be sure all exam materials are kept secure during the break. When the students return from break, turn to page 215 and begin the exam administration for Physics C: Electricity and Magnetism.

If you have no students taking Physics C: Electricity and Magnetism, all exam materials should be put in secure storage until they are returned to the AP Program after your school's last administration. Before storing materials, check the "School Use Only" section on page 1 of the answer sheet and:

- Fill in the appropriate section number circle in order to access a separate AP Instructional Planning Report (for regularly scheduled exams only) or subject score roster at the class section or teacher level. See "Post-Exam Activities" in the *2012-13 AP Coordinator's Manual*.
- Check your list of students who are eligible for fee reductions and fill in the appropriate circle on their registration answer sheets.

Student Answer Sheet for the Multiple-Choice Section

Use this section to capture student responses. (Note that the following answer sheet is a sample, and may differ from one used in an actual exam.)

Section I: Multiple-Choice Questions

This is the multiple-choice section of the 2013 AP exam. It includes cover material and other administrative instructions to help familiarize students with the mechanics of the exam. (Note that future exams may differ in look from the following content.)

AP[®] Physics C: Mechanics Exam**SECTION I: Multiple Choice****2013****DO NOT OPEN THIS BOOKLET UNTIL YOU ARE TOLD TO DO SO.****At a Glance****Total Time**

45 minutes

Number of Questions

35

Percent of Total Score

50%

Writing Instrument

Pencil required

Electronic Device

None allowed

Instructions

Section I of this exam contains 35 multiple-choice questions. For these questions, fill in only the circles for numbers 1 through 35 on your answer sheet. A table of information that may be helpful is in the booklet. Rulers and straightedges may be used in this section.

Indicate all of your answers to the multiple-choice questions on the answer sheet. No credit will be given for anything written in this exam booklet, but you may use the booklet for notes or scratch work. After you have decided which of the suggested answers is best, completely fill in the corresponding circle on the answer sheet. Give only one answer to each question. If you change an answer, be sure that the previous mark is erased completely. Here is a sample question and answer.

Sample Question Sample Answer

Chicago is a (A) ● (C) (D) (E)
 (A) state
 (B) city
 (C) country
 (D) continent
 (E) village

Use your time effectively, working as quickly as you can without losing accuracy. Do not spend too much time on any one question. Go on to other questions and come back to the ones you have not answered if you have time. It is not expected that everyone will know the answers to all of the multiple-choice questions.

Your total score on the multiple-choice section is based only on the number of questions answered correctly. Points are not deducted for incorrect answers or unanswered questions.

TABLE OF INFORMATION DEVELOPED FOR 2012

CONSTANTS AND CONVERSION FACTORS	
Proton mass, $m_p = 1.67 \times 10^{-27}$ kg	Electron charge magnitude, $e = 1.60 \times 10^{-19}$ C
Neutron mass, $m_n = 1.67 \times 10^{-27}$ kg	1 electron volt, $1 \text{ eV} = 1.60 \times 10^{-19}$ J
Electron mass, $m_e = 9.11 \times 10^{-31}$ kg	Speed of light, $c = 3.00 \times 10^8$ m/s
Avogadro's number, $N_0 = 6.02 \times 10^{23}$ mol ⁻¹	Universal gravitational constant, $G = 6.67 \times 10^{-11}$ m ³ /kg·s ²
Universal gas constant, $R = 8.31$ J/(mol·K)	Acceleration due to gravity at Earth's surface, $g = 9.8$ m/s ²
Boltzmann's constant, $k_B = 1.38 \times 10^{-23}$ J/K	
1 unified atomic mass unit,	$1 \text{ u} = 1.66 \times 10^{-27}$ kg = $931 \text{ MeV}/c^2$
Planck's constant,	$h = 6.63 \times 10^{-34}$ J·s = 4.14×10^{-15} eV·s
	$hc = 1.99 \times 10^{-25}$ J·m = 1.24×10^3 eV·nm
Vacuum permittivity,	$\epsilon_0 = 8.85 \times 10^{-12}$ C ² /N·m ²
Coulomb's law constant, $k = 1/4\pi\epsilon_0 = 9.0 \times 10^9$ N·m ² /C ²	
Vacuum permeability,	$\mu_0 = 4\pi \times 10^{-7}$ (T·m)/A
Magnetic constant, $k' = \mu_0/4\pi = 1 \times 10^{-7}$ (T·m)/A	
1 atmosphere pressure,	$1 \text{ atm} = 1.0 \times 10^5$ N/m ² = 1.0×10^5 Pa

UNIT SYMBOLS	meter,	m	mole,	mol	watt,	W	farad,	F
	kilogram,	kg	hertz,	Hz	coulomb,	C	tesla,	T
	second,	s	newton,	N	volt,	V	degree Celsius,	°C
	ampere,	A	pascal,	Pa	ohm,	Ω	electron-volt,	eV
	kelvin,	K	joule,	J	henry,	H		

PREFIXES		
Factor	Prefix	Symbol
10^9	giga	G
10^6	mega	M
10^3	kilo	k
10^{-2}	centi	c
10^{-3}	milli	m
10^{-6}	micro	μ
10^{-9}	nano	n
10^{-12}	pico	p

VALUES OF TRIGONOMETRIC FUNCTIONS FOR COMMON ANGLES							
θ	0°	30°	37°	45°	53°	60°	90°
$\sin \theta$	0	1/2	3/5	$\sqrt{2}/2$	4/5	$\sqrt{3}/2$	1
$\cos \theta$	1	$\sqrt{3}/2$	4/5	$\sqrt{2}/2$	3/5	1/2	0
$\tan \theta$	0	$\sqrt{3}/3$	3/4	1	4/3	$\sqrt{3}$	∞

The following conventions are used in this exam.

- I. Unless otherwise stated, the frame of reference of any problem is assumed to be inertial.
- II. The direction of any electric current is the direction of flow of positive charge (conventional current).
- III. For any isolated electric charge, the electric potential is defined as zero at an infinite distance from the charge.

PHYSICS C: MECHANICS

SECTION I

Time—45 minutes

35 Questions

Directions: Each of the questions or incomplete statements below is followed by five suggested answers or completions. Select the one that is best in each case and then fill in the corresponding circle on the answer sheet.

Note: To simplify calculations, you may use $g = 10 \text{ m/s}^2$ in all problems.

Questions 1-3

An object of mass 10 kg starts from rest at time $t = 0$ and moves in a straight line. For time $t > 0$, the object's velocity v as a function of time t is given by $v = 2t + 3t^2$, where v is in m/s and t is in seconds.

- How far does the object travel during the first 10 s of its motion?
(A) 62 m
(B) 320 m
(C) 383 m
(D) 1100 m
(E) 1600 m
- What is the instantaneous net force that acts on the object at $t = 2$ s?
(A) 140 N
(B) 160 N
(C) 320 N
(D) 1280 N
(E) 2560 N
- How much work is done by the net force between $t = 0$ and $t = 1$ s?
(A) 5 J
(B) 50 J
(C) 125 J
(D) 250 J
(E) 500 J
- Persons X, Y, and Z walk along a circular path of radius 50 m. Person X walks halfway around the path, Person Y walks $3/4$ of the way around the path, and Person Z walks completely around the path. Which of the following correctly lists the walkers in order of the magnitudes of their displacement vectors from the least to the greatest?
(A) $X < Y < Z$
(B) $X < Z < Y$
(C) $Y < X < Z$
(D) $Y < Z < X$
(E) $Z < Y < X$
- A small particle starts from rest from the origin of an xy -coordinate system and travels in the xy -plane. Its acceleration in the x -direction is 2.0 m/s^2 , and its acceleration in the y -direction is 1.0 m/s^2 . What is the x -coordinate of the particle when its y -coordinate is 12 m?
(A) 3.0 m
(B) 6.0 m
(C) 12 m
(D) 24 m
(E) 48 m
- If the speed of an object moving in a straight line is increasing at a constant rate, the net force acting on the object is
(A) zero
(B) constant, but not zero
(C) decreasing at a constant rate
(D) increasing at a constant rate
(E) changing at a rate proportional to the average velocity

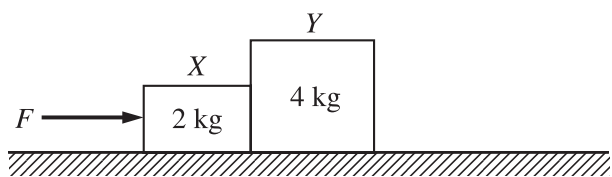

7. A force F accelerates a system of two blocks, X and Y , on a horizontal frictionless surface, as shown above. The acceleration is 4 m/s^2 . The force with which block Y pushes on block X has magnitude

- (A) zero
- (B) 6 N
- (C) 8 N
- (D) 16 N
- (E) 24 N

8. A hoop of mass m and radius r rolls with constant speed on a horizontal surface without slipping. What is the hoop's translational kinetic energy divided by its rotational kinetic energy?

- (A) 4
- (B) 2
- (C) 1
- (D) $1/2$
- (E) $1/4$

9. The rotational inertia of a sphere of mass M and radius R about a diameter is $\frac{2}{5}MR^2$. The rotational inertia about an axis tangent to the sphere is

- (A) $\frac{3}{2}MR^2$
- (B) $\frac{7}{5}MR^2$
- (C) MR^2
- (D) $\frac{1}{2}MR^2$
- (E) $\frac{2}{5}MR^2$

10. All of the following are vector quantities EXCEPT

- (A) rotational kinetic energy
- (B) torque
- (C) angular momentum
- (D) angular velocity
- (E) centripetal acceleration

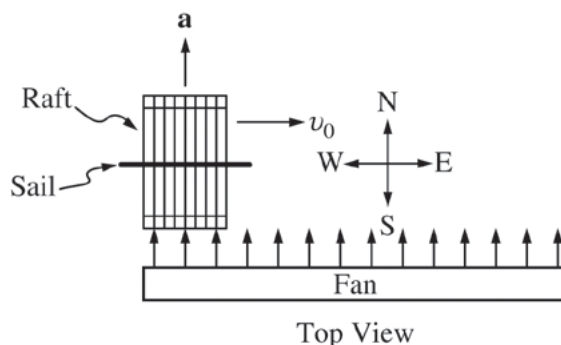

11. The toy raft shown in the top view above is sliding due east on frictionless ice at constant speed v_0 when a fan blows on its sail, producing a constant acceleration \mathbf{a} directed to the north. Which of the following could indicate the path of the raft while the fan is blowing?

- (A)
- (B)
- (C)
- (D)
- (E)

12. The velocity v in meters per second of an object moving in a straight line is given as a function of time t in seconds by $v = 4t^3 + 2t$. The total distance the object travels between $t = 1$ s and $t = 2$ s is

- (A) 12 m
- (B) 18 m
- (C) 24 m
- (D) 30 m
- (E) 36 m

13. Two small spheres, each with a mass of 3.0 kg, are placed 6.0 m apart. Which of the following is the order of magnitude of the gravitational attraction between them?

- (A) 10^{-15} N
- (B) 10^{-13} N
- (C) 10^{-11} N
- (D) 10^{-9} N
- (E) 10^{-7} N

14. A satellite of mass m is in a circular orbit with speed v_0 at a distance r from the center of Earth. What is the ratio of its escape speed from the orbit to its orbital speed, v_e/v_0 ?

- (A) $\sqrt{2}$
- (B) 2
- (C) 1
- (D) $\frac{1}{2}$
- (E) $\frac{1}{\sqrt{2}}$

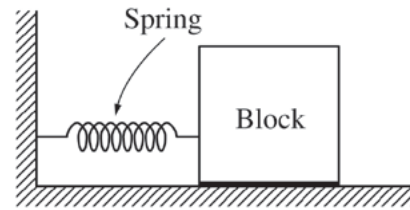

15. The block shown above is attached to a rigid wall by means of an ideal spring and moves on a horizontal surface with negligible friction. The block oscillates with a period T . If a second ideal spring, identical to the first, is placed above the first spring and attached to the wall and the block, the new oscillation period of the block is

- (A) $T/2$
- (B) $T/\sqrt{2}$
- (C) T
- (D) $\sqrt{2}T$
- (E) $2T$

16. An object on the end of a spring of force constant k moves in simple harmonic motion with amplitude A and frequency f . Which of the following is a possible expression for the potential energy of the spring as a function of time t ?

- (A) $\frac{1}{2}kA^2 \sin^2(2\pi ft)$
- (B) $kA^2 \cos^2(2\pi ft)$
- (C) $kA \sin(2\pi ft)$
- (D) $\frac{1}{2}kA \cos(2\pi ft)$
- (E) $kA(\sin 2\pi ft + \cos 2\pi ft)$

17. A wheel with rotational inertia $0.04 \text{ kg}\cdot\text{m}^2$ and radius 0.02 m is turning at the rate of 10 revolutions per second when a frictional torque is applied to stop it. How much work is done by the torque in stopping the wheel?

- (A) -0.0008 J
 (B) $-0.4\pi \text{ J}$
 (C) -2 J
 (D) $-2\pi^2 \text{ J}$
 (E) $-8\pi^2 \text{ J}$

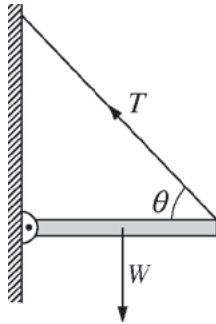

18. A uniform beam of weight W is attached to a wall by a pivot at one end and is held horizontal by a cable attached to the other end of the beam and to the wall, as shown above. T is the tension in the cable, which makes an angle θ with the beam. Which of the following is equal to T ?

- (A) $\frac{W}{2 \cos \theta}$
 (B) $\frac{W}{2 \sin \theta}$
 (C) $\frac{W}{\cos \theta}$
 (D) $\frac{W}{\sin \theta}$
 (E) W

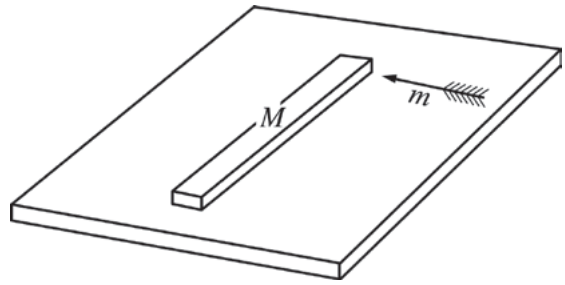

19. An arrow of mass m and speed v_0 strikes and sticks to one end of a meterstick of mass M as shown in the diagram above. The meterstick is initially at rest on a horizontal surface and free to move without friction. The speed of the center of mass of the stick-arrow system after the arrow strikes is given by which of the following expressions?

- (A) $\frac{1}{2}(M + m)v_0^2$
 (B) $\frac{mv_0}{M}$
 (C) $\frac{mv_0}{M + m}$
 (D) $\frac{v_0}{2}$
 (E) 0

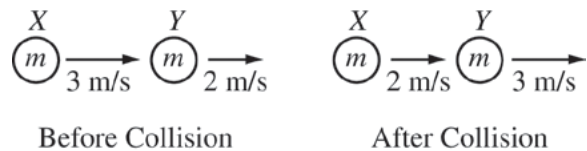

20. Object X of mass m is moving to the right with a speed of 3 m/s when it collides with object Y of mass m that is moving to the right with a speed of 2 m/s , as shown above. After the collision, X is moving to the right with a speed of 2 m/s and Y is moving to the right with a speed of 3 m/s . Which of the following is true of the collision?

- (A) It is elastic because momentum is conserved.
 (B) It is elastic because kinetic energy is conserved.
 (C) It is inelastic because momentum is not conserved.
 (D) It is inelastic because kinetic energy is not conserved.
 (E) More information is needed to determine whether the collision is elastic or inelastic.

Questions 21-22

A 20 kg box moving at an initial speed of 10 m/s slides 25 m to the right on a horizontal floor before it comes to a complete stop.

21. What is the coefficient of friction between the box and the floor?

- (A) 0.10
- (B) 0.20
- (C) 0.40
- (D) 0.60
- (E) 0.80

22. Which of the following best describes the frictional forces exerted on the box and on the floor while the box is sliding?

<u>Box</u>	<u>Floor</u>
(A) None	None
(B) To the right	To the right
(C) To the right	To the left
(D) To the left	None
(E) To the left	To the right

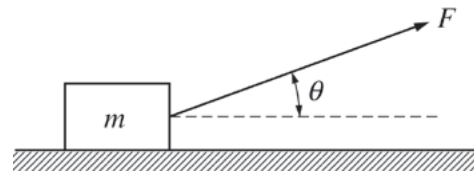

23. A block of mass m is pulled across a rough horizontal surface at constant speed by a force of magnitude F , which acts at an angle of θ to the horizontal, as shown above. The coefficient of kinetic friction between the block and the surface is

- (A) $\frac{F}{mg}$
- (B) $\frac{F \sin \theta}{mg}$
- (C) $\frac{F \cos \theta}{mg}$
- (D) $\frac{F \sin \theta}{mg - F \cos \theta}$
- (E) $\frac{F \cos \theta}{mg - F \sin \theta}$

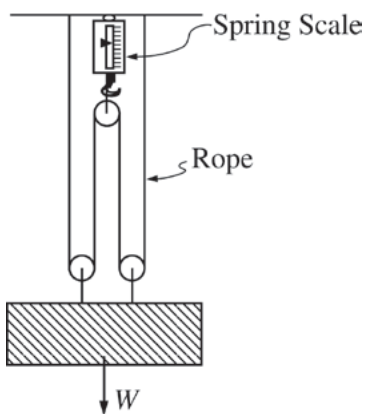

24. The rope-and-pulley system of negligible mass shown above supports a block of weight W that is at rest. If the tension throughout the rope is uniform, what is the reading on the spring scale?

- (A) W
- (B) $\frac{W}{2}$
- (C) $\frac{W}{3}$
- (D) $\frac{W}{4}$
- (E) $\frac{W}{8}$

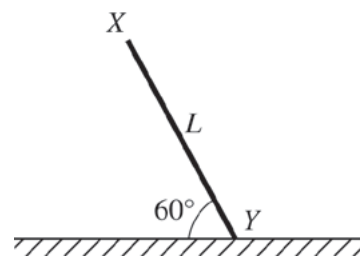

25. The uniform rod of length L shown above is supported by holding end X so that the rod makes an angle 60° with the horizontal floor. There is no friction acting between the rod and the floor. When the support at X is removed, the rod falls under the influence of gravity. Which of the following best describes the movement of end Y as the rod falls?

- (A) It moves $\frac{1}{2}L$ to the left.
- (B) It remains at rest.
- (C) It moves $\frac{1}{4}L$ to the right.
- (D) It moves $\frac{1}{2}L$ to the right.
- (E) It moves $\frac{3}{4}L$ to the right.

26. In an experiment, an object is released from rest from the top of a building. Its speed v is measured as it reaches a point that is a distance d from the point of release. If this distance was doubled, what would the new speed be, assuming air resistance is negligible?

- (A) v
- (B) $\sqrt{2}v$
- (C) $2v$
- (D) $4v$
- (E) $8v$

27. A particle moves on a straight line with a speed v that changes with time t according to the equation $v = v_0 e^{-\beta t}$, where v_0 and β are constants. The acceleration a of the particle is related to its speed by which of the following equations?
- (A) $a = -\beta v$
 (B) $a = -\beta v^2$
 (C) $a = -\beta vt$
 (D) $a = -v/t$
 (E) $a = -v_0/t$
28. The relationship between the magnitude of the restoring force F and the resultant displacement x from equilibrium for a nonlinear spring is given by the equation $F = kx^2$. What is the potential energy of the spring when it has been compressed a distance x_0 ?
- (A) kx_0^3
 (B) $\frac{1}{2} kx_0^2$
 (C) $\frac{1}{2} kx_0^3$
 (D) $\frac{1}{3} kx_0^2$
 (E) $\frac{1}{3} kx_0^3$
29. The period T of a pendulum of length L is measured to determine g at the surface of Earth. The equation used is $T = 2\pi\sqrt{L/g}$. The mass of the pendulum bob is 10.0 kg, and the length of the pendulum is 1.00 m. Which of the following would contribute most to the expected error in the result?
- (A) A 10% uncertainty in the measurement of the mass
 (B) Approximating the value of π as 3.14
 (C) Variation in the value of g as the pendulum bob moves along its arc
 (D) Using the average period of 10 timed oscillations instead of the period of 1 timed oscillation
 (E) Starting the pendulum swinging by releasing it from a horizontal position
30. If a person goes to the bottom of a deep mine shaft on a planet of uniform density, which of the following is true?
- (A) The person's weight is exactly the same as at the surface.
 (B) The person's weight is greater than at the surface.
 (C) The person's weight is less than at the surface.
 (D) The person's weight may increase or decrease, depending on the density of the planet.
 (E) The gravitational force on the person changes in direction but not in magnitude.

31. A certain satellite in a circular orbit of radius r remains vertically above a certain point on Earth's equator. Which of the following expressions correctly gives r in terms of ω (the angular velocity of Earth's rotation about its axis), M (the mass of Earth), and G (the universal gravitational constant) ?

- (A) $r = \frac{\omega^2}{GM}$
(B) $r = \frac{GM}{\omega}$
(C) $r^2 = \frac{GM}{\omega}$
(D) $r^3 = \omega^2 GM$
(E) $r^3 = \frac{GM}{\omega^2}$

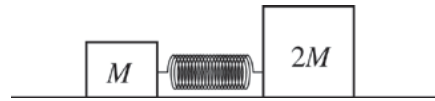

32. Two blocks of masses M and $2M$ are on a frictionless horizontal surface, as shown above, and are held in place with a compressed spring of negligible mass between them. If the blocks are then released and the block of mass $2M$ leaves the spring with a velocity v , the velocity of the center of mass of the blocks is

- (A) zero
(B) $-\frac{v}{2}$
(C) $-\frac{2v}{3}$
(D) $-\frac{3v}{2}$
(E) $-2v$

Questions 33-34

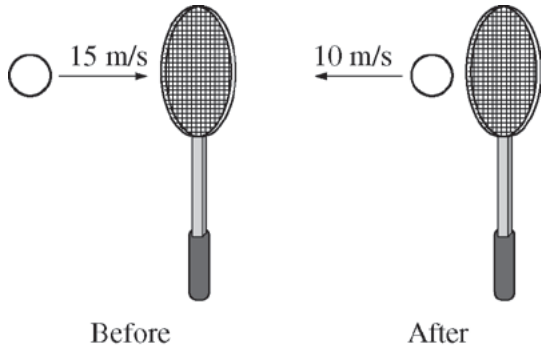

A 0.060 kg tennis ball moving at 15 m/s strikes a tennis racket and rebounds at 10 m/s in the opposite direction, as shown above. The ball is in contact with the racket for 0.030 s.

33. What is the magnitude of the average force exerted by the racket on the ball?
- (A) 5 N
 - (B) 10 N
 - (C) 20 N
 - (D) 25 N
 - (E) 50 N
34. How does the magnitude of the average force exerted by the ball on the racket compare to the magnitude of the average force exerted by the racket on the ball?
- (A) It is less.
 - (B) It is equal.
 - (C) It is greater.
 - (D) It cannot be determined without knowing the mass of the racket.
 - (E) It cannot be determined without knowing the recoil speed of the racket.

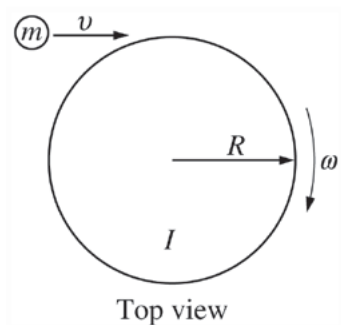

35. A circular platform has a radius R and rotational inertia I . The platform rotates around a fixed pivot at its center with negligible friction and an initial angular velocity ω . A child of mass m (represented by the small circle in the figure above) runs tangentially with speed v and jumps on the outer edge of the platform. When the child is standing on the outer edge of the platform, the new angular velocity is

- (A) ω
- (B) $\frac{I\omega}{I + mR^2}$
- (C) $\frac{I\omega + mvR}{I + mR^2}$
- (D) $\left(\frac{I\omega^2 + mv^2}{I}\right)^{1/2}$
- (E) $\left(\frac{I\omega^2 + mv^2}{I + mR^2}\right)^{1/2}$

S T O P

END OF MECHANICS SECTION I

**IF YOU FINISH BEFORE TIME IS CALLED,
YOU MAY CHECK YOUR WORK ON MECHANICS SECTION I ONLY.**

DO NOT TURN TO ANY OTHER TEST MATERIALS.

MAKE SURE YOU HAVE DONE THE FOLLOWING.

- **PLACED YOUR AP NUMBER LABEL ON YOUR ANSWER SHEET**
- **WRITTEN AND GRIDDED YOUR AP NUMBER CORRECTLY ON YOUR ANSWER SHEET**
- **TAKEN THE AP EXAM LABEL FROM THE FRONT OF THIS BOOKLET AND PLACED IT ON YOUR ANSWER SHEET**

Section II: Free-Response Questions

This is the free-response section of the 2013 AP exam. It includes cover material and other administrative instructions to help familiarize students with the mechanics of the exam. (Note that future exams may differ in look from the following content.)

AP[®] Physics C: Mechanics Exam

SECTION II: Free Response

2013

DO NOT OPEN THIS BOOKLET UNTIL YOU ARE TOLD TO DO SO.

At a Glance

Total Time

45 minutes

Number of Questions

3

Percent of Total Score

50%

Writing Instrument

Either pencil or pen with black or dark blue ink

Electronic Device

Calculator allowed

Weight

The questions are weighted equally.

IMPORTANT Identification Information

PLEASE PRINT WITH PEN:

1. First two letters of your last name
First letter of your first name
2. Date of birth

Month Day Year
3. Six-digit school code
4. Unless I check the box below, I grant the College Board the unlimited right to use, reproduce, and publish my free-response materials, both written and oral, for educational research and instructional purposes. My name and the name of my school will not be used in any way in connection with my free-response materials. I understand that I am free to mark "No" with no effect on my score or its reporting.
No, I do not grant the College Board these rights.

Instructions

The questions for Section II are printed in this booklet. You may use any blank space in the booklet for scratch work, but you must write your answers in the spaces provided for each answer. A table of information and lists of equations that may be helpful are in the booklet. Calculators, rulers, and straightedges may be used in this section.

All final numerical answers should include appropriate units. Credit for your work depends on demonstrating that you know which physical principles would be appropriate to apply in a particular situation. Therefore, you should show your work for each part in the space provided after that part. If you need more space, be sure to clearly indicate where you continue your work. Credit will be awarded only for work that is clearly designated as the solution to a specific part of a question. Credit also depends on the quality of your solutions and explanations, so you should show your work.

Write clearly and legibly. Cross out any errors you make; erased or crossed-out work will not be scored. You may lose credit for incorrect work that is not crossed out.

Manage your time carefully. You may proceed freely from one question to the next. You may review your responses if you finish before the end of the exam is announced.

Form I
Form Code Z-4BBP2-S2

80

TABLE OF INFORMATION DEVELOPED FOR 2012

CONSTANTS AND CONVERSION FACTORS	
Proton mass, $m_p = 1.67 \times 10^{-27}$ kg	Electron charge magnitude, $e = 1.60 \times 10^{-19}$ C
Neutron mass, $m_n = 1.67 \times 10^{-27}$ kg	1 electron volt, $1 \text{ eV} = 1.60 \times 10^{-19}$ J
Electron mass, $m_e = 9.11 \times 10^{-31}$ kg	Speed of light, $c = 3.00 \times 10^8$ m/s
Avogadro's number, $N_0 = 6.02 \times 10^{23}$ mol ⁻¹	Universal gravitational constant, $G = 6.67 \times 10^{-11}$ m ³ /kg·s ²
Universal gas constant, $R = 8.31$ J/(mol·K)	Acceleration due to gravity at Earth's surface, $g = 9.8$ m/s ²
Boltzmann's constant, $k_B = 1.38 \times 10^{-23}$ J/K	
1 unified atomic mass unit,	$1 \text{ u} = 1.66 \times 10^{-27}$ kg = $931 \text{ MeV}/c^2$
Planck's constant,	$h = 6.63 \times 10^{-34}$ J·s = 4.14×10^{-15} eV·s
	$hc = 1.99 \times 10^{-25}$ J·m = 1.24×10^3 eV·nm
Vacuum permittivity,	$\epsilon_0 = 8.85 \times 10^{-12}$ C ² /N·m ²
Coulomb's law constant, $k = 1/4\pi\epsilon_0 = 9.0 \times 10^9$ N·m ² /C ²	
Vacuum permeability,	$\mu_0 = 4\pi \times 10^{-7}$ (T·m)/A
Magnetic constant, $k' = \mu_0/4\pi = 1 \times 10^{-7}$ (T·m)/A	
1 atmosphere pressure,	$1 \text{ atm} = 1.0 \times 10^5$ N/m ² = 1.0×10^5 Pa

UNIT SYMBOLS	meter, m	mole, mol	watt, W	farad, F
	kilogram, kg	hertz, Hz	coulomb, C	tesla, T
	second, s	newton, N	volt, V	degree Celsius, °C
	ampere, A	pascal, Pa	ohm, Ω	electron-volt, eV
	kelvin, K	joule, J	henry, H	

PREFIXES		
Factor	Prefix	Symbol
10^9	giga	G
10^6	mega	M
10^3	kilo	k
10^{-2}	centi	c
10^{-3}	milli	m
10^{-6}	micro	μ
10^{-9}	nano	n
10^{-12}	pico	p

VALUES OF TRIGONOMETRIC FUNCTIONS FOR COMMON ANGLES							
θ	0°	30°	37°	45°	53°	60°	90°
$\sin \theta$	0	1/2	3/5	$\sqrt{2}/2$	4/5	$\sqrt{3}/2$	1
$\cos \theta$	1	$\sqrt{3}/2$	4/5	$\sqrt{2}/2$	3/5	1/2	0
$\tan \theta$	0	$\sqrt{3}/3$	3/4	1	4/3	$\sqrt{3}$	∞

The following conventions are used in this exam.

- I. Unless otherwise stated, the frame of reference of any problem is assumed to be inertial.
- II. The direction of any electric current is the direction of flow of positive charge (conventional current).
- III. For any isolated electric charge, the electric potential is defined as zero at an infinite distance from the charge.

ADVANCED PLACEMENT PHYSICS C EQUATIONS DEVELOPED FOR 2012

MECHANICS

$v = v_0 + at$	$a = \text{acceleration}$
$x = x_0 + v_0t + \frac{1}{2}at^2$	$F = \text{force}$
$v^2 = v_0^2 + 2a(x - x_0)$	$f = \text{frequency}$
$\Sigma \mathbf{F} = \mathbf{F}_{net} = m\mathbf{a}$	$h = \text{height}$
$\mathbf{F} = \frac{d\mathbf{p}}{dt}$	$I = \text{rotational inertia}$
$\mathbf{J} = \int \mathbf{F} dt = \Delta \mathbf{p}$	$J = \text{impulse}$
$\mathbf{p} = m\mathbf{v}$	$K = \text{kinetic energy}$
$F_{fric} \leq \mu N$	$k = \text{spring constant}$
$W = \int \mathbf{F} \cdot d\mathbf{r}$	$\ell = \text{length}$
$K = \frac{1}{2}mv^2$	$L = \text{angular momentum}$
$P = \frac{dW}{dt}$	$m = \text{mass}$
$P = \mathbf{F} \cdot \mathbf{v}$	$N = \text{normal force}$
$\Delta U_g = mgh$	$P = \text{power}$
$a_c = \frac{v^2}{r} = \omega^2 r$	$p = \text{momentum}$
$\boldsymbol{\tau} = \mathbf{r} \times \mathbf{F}$	$r = \text{radius or distance}$
$\Sigma \boldsymbol{\tau} = \boldsymbol{\tau}_{net} = I\boldsymbol{\alpha}$	$\mathbf{r} = \text{position vector}$
$I = \int r^2 dm = \Sigma mr^2$	$T = \text{period}$
$\mathbf{r}_{cm} = \Sigma m\mathbf{r} / \Sigma m$	$t = \text{time}$
$v = r\omega$	$U = \text{potential energy}$
$\mathbf{L} = \mathbf{r} \times \mathbf{p} = I\boldsymbol{\omega}$	$v = \text{velocity or speed}$
$K = \frac{1}{2}I\omega^2$	$W = \text{work done on a system}$
$\omega = \omega_0 + \alpha t$	$x = \text{position}$
$\theta = \theta_0 + \omega_0 t + \frac{1}{2}\alpha t^2$	$\mu = \text{coefficient of friction}$
	$\theta = \text{angle}$
	$\tau = \text{torque}$
	$\omega = \text{angular speed}$
	$\alpha = \text{angular acceleration}$
	$\phi = \text{phase angle}$
	$\mathbf{F}_s = -k\mathbf{x}$
	$U_s = \frac{1}{2}kx^2$
	$x = x_{\max} \cos(\omega t + \phi)$
	$T = \frac{2\pi}{\omega} = \frac{1}{f}$
	$T_s = 2\pi\sqrt{\frac{m}{k}}$
	$T_p = 2\pi\sqrt{\frac{\ell}{g}}$
	$\mathbf{F}_G = -\frac{Gm_1m_2}{r^2} \hat{\mathbf{r}}$
	$U_G = -\frac{Gm_1m_2}{r}$

ELECTRICITY AND MAGNETISM

$F = \frac{1}{4\pi\epsilon_0} \frac{q_1q_2}{r^2}$	$A = \text{area}$
$\mathbf{E} = \frac{\mathbf{F}}{q}$	$B = \text{magnetic field}$
$\oint \mathbf{E} \cdot d\mathbf{A} = \frac{Q}{\epsilon_0}$	$C = \text{capacitance}$
$E = -\frac{dV}{dr}$	$d = \text{distance}$
$V = \frac{1}{4\pi\epsilon_0} \sum_i \frac{q_i}{r_i}$	$E = \text{electric field}$
$U_E = qV = \frac{1}{4\pi\epsilon_0} \frac{q_1q_2}{r}$	$\mathcal{E} = \text{emf}$
$C = \frac{Q}{V}$	$F = \text{force}$
$C = \frac{\kappa\epsilon_0 A}{d}$	$I = \text{current}$
$C_p = \sum_i C_i$	$J = \text{current density}$
$\frac{1}{C_s} = \sum_i \frac{1}{C_i}$	$L = \text{inductance}$
$I = \frac{dQ}{dt}$	$\ell = \text{length}$
$U_c = \frac{1}{2}QV = \frac{1}{2}CV^2$	$n = \text{number of loops of wire per unit length}$
$R = \frac{\rho\ell}{A}$	$N = \text{number of charge carriers per unit volume}$
$\mathbf{E} = \rho\mathbf{J}$	$P = \text{power}$
$I = Nev_d A$	$Q = \text{charge}$
$V = IR$	$q = \text{point charge}$
$R_s = \sum_i R_i$	$R = \text{resistance}$
$\frac{1}{R_p} = \sum_i \frac{1}{R_i}$	$r = \text{distance}$
$P = IV$	$t = \text{time}$
$\mathbf{F}_M = q\mathbf{v} \times \mathbf{B}$	$U = \text{potential or stored energy}$
	$V = \text{electric potential}$
	$v = \text{velocity or speed}$
	$\rho = \text{resistivity}$
	$\phi_m = \text{magnetic flux}$
	$\kappa = \text{dielectric constant}$
	$\oint \mathbf{B} \cdot d\boldsymbol{\ell} = \mu_0 I$
	$d\mathbf{B} = \frac{\mu_0}{4\pi} \frac{I d\boldsymbol{\ell} \times \mathbf{r}}{r^3}$
	$\mathbf{F} = \int I d\boldsymbol{\ell} \times \mathbf{B}$
	$B_s = \mu_0 n I$
	$\phi_m = \int \mathbf{B} \cdot d\mathbf{A}$
	$\boldsymbol{\mathcal{E}} = \oint \mathbf{E} \cdot d\boldsymbol{\ell} = -\frac{d\phi_m}{dt}$
	$\boldsymbol{\mathcal{E}} = -L \frac{dI}{dt}$
	$U_L = \frac{1}{2} LI^2$

ADVANCED PLACEMENT PHYSICS C EQUATIONS DEVELOPED FOR 2012

GEOMETRY AND TRIGONOMETRY

Rectangle

$$A = bh$$

Triangle

$$A = \frac{1}{2}bh$$

Circle

$$A = \pi r^2$$

$$C = 2\pi r$$

Rectangular Solid

$$V = \ell wh$$

Cylinder

$$V = \pi r^2 \ell$$

$$S = 2\pi r \ell + 2\pi r^2$$

Sphere

$$V = \frac{4}{3}\pi r^3$$

$$S = 4\pi r^2$$

Right Triangle

$$a^2 + b^2 = c^2$$

$$\sin \theta = \frac{a}{c}$$

$$\cos \theta = \frac{b}{c}$$

$$\tan \theta = \frac{a}{b}$$

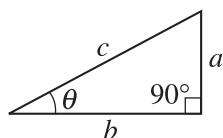

CALCULUS

$$\frac{df}{dx} = \frac{df}{du} \frac{du}{dx}$$

$$\frac{d}{dx}(x^n) = nx^{n-1}$$

$$\frac{d}{dx}(e^x) = e^x$$

$$\frac{d}{dx}(\ln x) = \frac{1}{x}$$

$$\frac{d}{dx}(\sin x) = \cos x$$

$$\frac{d}{dx}(\cos x) = -\sin x$$

$$\int x^n dx = \frac{1}{n+1} x^{n+1}, n \neq -1$$

$$\int e^x dx = e^x$$

$$\int \frac{dx}{x} = \ln|x|$$

$$\int \cos x dx = \sin x$$

$$\int \sin x dx = -\cos x$$

PHYSICS C: MECHANICS

SECTION II

Time—45 minutes

3 Questions

Directions: Answer all three questions. The suggested time is about 15 minutes for answering each of the questions, which are worth 15 points each. The parts within a question may not have equal weight. Show all your work in this booklet in the spaces provided after each part.

Mech. 1.

A ball of mass m and cross-sectional area A is released from rest near the surface of Earth. The ball experiences a resistive force due to the air that is proportional to the ball's velocity, $\mathbf{F}_r = -bA\mathbf{v}$, where b is a positive constant. Determine all algebraic answers in terms of m , b , A , and fundamental constants.

- (a) Draw free-body diagrams for the ball for the following situations. Give each vector a descriptive label and draw them approximately to scale.

A Short Time After
the Ball is Released

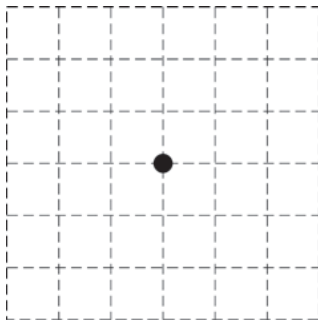

Once the Ball Has Reached
Terminal Velocity

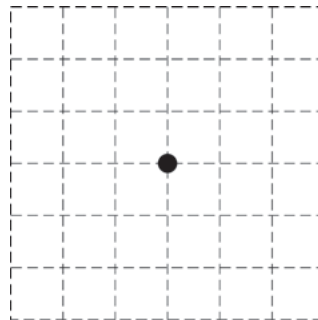

- (b) Calculate the terminal velocity v_T of the ball.

(c) Starting from Newton's laws, derive an expression for the time required for the ball to reach one third the terminal velocity.

(d) Sketch the following two graphs of the ball's motion from when the ball is released at time $t = 0$ until it approaches terminal velocity.

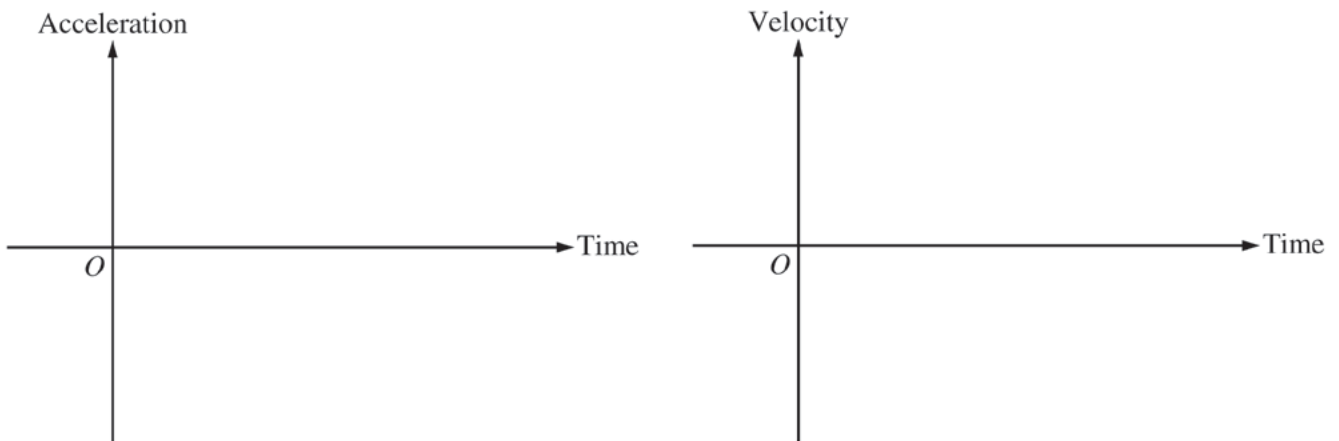

Mech. 2.

A 0.30 kg cart moving at 2.0 m/s to the right collides with a 0.10 kg cart, initially moving at 3.0 m/s to the left. After the collision, the 0.10 kg cart moves to the right with a speed of 1.2 m/s. Assume friction is negligible.

(a) Calculate the magnitude and direction of the velocity of the 0.30 kg cart after the collision.

(b) Is this an elastic collision? Justify your answer.

The 0.30 kg cart is now removed. The 0.10 kg cart continues to move to the right and then collides with and compresses an ideal spring whose right end is attached to a fixed wall.

(c) Calculate the potential energy of the spring when it reaches maximum compression.

(d) The maximum compression of the spring is 0.10 m. Calculate the spring constant of the spring.

(e) Suppose instead that the spring is nonlinear such that the force F due to the spring when it is compressed a distance x is $F = -bx^3$. Calculate the value of the constant b if the spring is compressed 0.10 m.

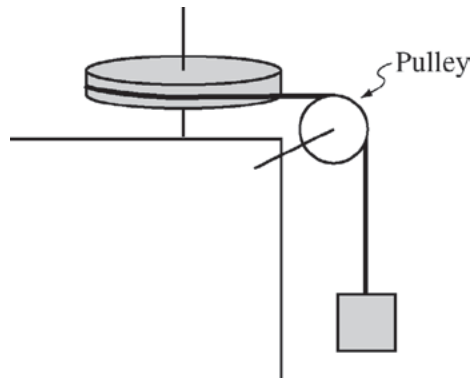

Mech. 3.

A solid disk of radius 0.10 m is mounted on a vertical axis. A string of negligible mass is wrapped around the rim of the disk; passes over a small, lightweight, frictionless pulley as shown above; and is tied to a block of mass 0.05 kg. The system is released from rest, and a computer records the velocity of the falling block as a function of time, as shown below.

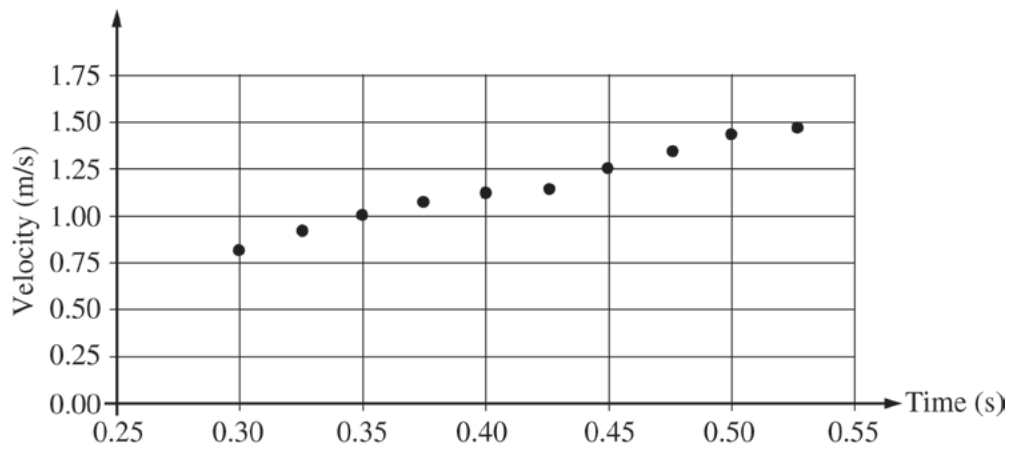

(a) Using the graph above, calculate the acceleration of the falling block.

(b) Use your result from part (a) to calculate the rotational inertia of the disk.

(c) Calculate the angular momentum of the disk at time $t = 0.45$ s.

(d) The disk is removed and replaced with a hoop of the same mass and radius, but with all of its mass concentrated near the rim of the hoop and connected to the axis by lightweight spokes. The experiment is then repeated. Is the angular acceleration of the hoop greater than, less than, or the same as that of the solid disk?

____ Greater than ____ Less than ____ The same

Justify your answer.

THIS PAGE MAY BE USED FOR SCRATCH WORK.

STOP

END OF EXAM

THE FOLLOWING INSTRUCTIONS APPLY TO THE COVERS OF THE SECTION II BOOKLET.

- **MAKE SURE YOU HAVE COMPLETED THE IDENTIFICATION INFORMATION AS REQUESTED ON THE FRONT AND BACK COVERS OF THE SECTION II BOOKLET.**
- **CHECK TO SEE THAT YOUR AP NUMBER LABEL APPEARS IN THE BOX(ES) ON THE COVER(S).**
- **MAKE SURE YOU HAVE USED THE SAME SET OF AP NUMBER LABELS ON ALL AP EXAMS YOU HAVE TAKEN THIS YEAR.**

Multiple-Choice Answer Key

The following contains the answers to the multiple-choice questions in this exam.

**Answer Key for AP Physics C: Mechanics
Practice Exam, Section I**

Question 1: D	Question 19: C
Question 2: A	Question 20: B
Question 3: C	Question 21: B
Question 4: E	Question 22: E
Question 5: D	Question 23: E
Question 6: B	Question 24: B
Question 7: D	Question 25: C
Question 8: C	Question 26: B
Question 9: B	Question 27: A
Question 10: A	Question 28: E
Question 11: A	Question 29: E
Question 12: B	Question 30: C
Question 13: C	Question 31: E
Question 14: A	Question 32: A
Question 15: B	Question 33: E
Question 16: A	Question 34: B
Question 17: E	Question 35: C
Question 18: B	

Free-Response Scoring Guidelines

The following contains the scoring guidelines
for the free-response questions in this exam.

**AP[®] PHYSICS C: MECHANICS
2013 SCORING GUIDELINES**

Question 1

15 points total

**Distribution
of points**

(a) 4 points

A Short Time After
the Ball is Released

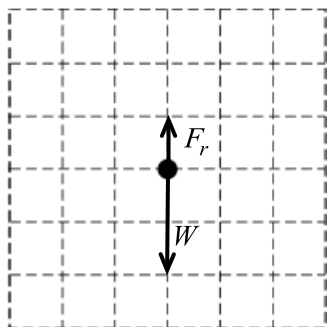

Once the Ball Has Reached
Terminal Velocity

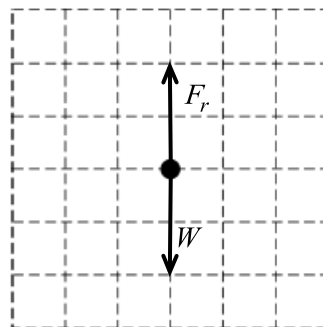

For having all four forces properly labeled and in the proper direction

1 point

For having both W vectors of equal length

1 point

For having $F_r < W$ a short time after the ball is released

1 point

For having $F_r = W$ at terminal velocity

1 point

Note: 1 earned point was deducted if there were any extraneous forces

(b) 2 points

For setting the resistive force equal to the weight when at terminal velocity

1 point

$$F_r = W$$

Substituting correct expressions for both forces

$$bAv_T = mg$$

For the correct magnitude of the terminal velocity

1 point

$$v_T = \frac{mg}{bA}$$

**AP[®] PHYSICS C: MECHANICS
2013 SCORING GUIDELINES**

Question 1 (continued)

**Distribution
of points**

(c) 4 points

For a correct differential equation expressing Newton's 2nd law

$$F = ma = mg - bAv$$

$$m \frac{dv}{dt} = mg - bAv$$

Solving the differential equation for v

$$\frac{m}{bA} \frac{dv}{dt} = \frac{mg}{bA} - v \text{ where } v_T = \frac{mg}{bA}$$

$$\frac{m}{bA} \frac{dv}{dt} = v_T - v$$

$$\frac{dv}{v_T - v} = \frac{bA}{m} dt$$

$$\int_0^v \frac{dv}{v_T - v} = \int_0^t \frac{bA}{m} dt$$

This is of the form $\int \frac{du}{u} = \ln|u|$, where $u = v_T - v$ and $du = -dv$.

$$[-\ln|v_T - v|]_0^v = \left[\frac{bA}{m} t \right]_0^t$$

$$\ln(v_T - v) - \ln(v_T) = -\frac{bA}{m} t$$

$$\ln\left(\frac{v_T - v}{v_T}\right) = -\frac{bA}{m} t$$

$$\frac{v_T - v}{v_T} = e^{-bAt/m}$$

$$v(t) = v_T(1 - e^{-bAt/m})$$

For a correct expression of velocity as a function of time

$$v(t) = \frac{mg}{bA}(1 - e^{-bAt/m})$$

For substituting $v_T/3$ into the above equation

$$v_T/3 = v_T(1 - e^{-bAt/m})$$

Solving the above equation for time

$$1/3 = 1 - e^{-bAt/m}$$

$$e^{-bAt/m} = 1 - 1/3 = 2/3$$

$$-bAt/m = \ln(2/3)$$

1 point

1 point

1 point

**AP[®] PHYSICS C: MECHANICS
2013 SCORING GUIDELINES**

Question 1 (continued)

**Distribution
of points**

For a correct answer

1 point

$$t = -\frac{m}{bA} \ln\left(\frac{2}{3}\right) \text{ (negative sign required) or } t = \frac{m}{bA} \ln\left(\frac{3}{2}\right) \text{ (with no negative sign)}$$

Note: If the differential equation is incorrect, the student could still earn credit for solving the equation and substituting.

(d) 5 points

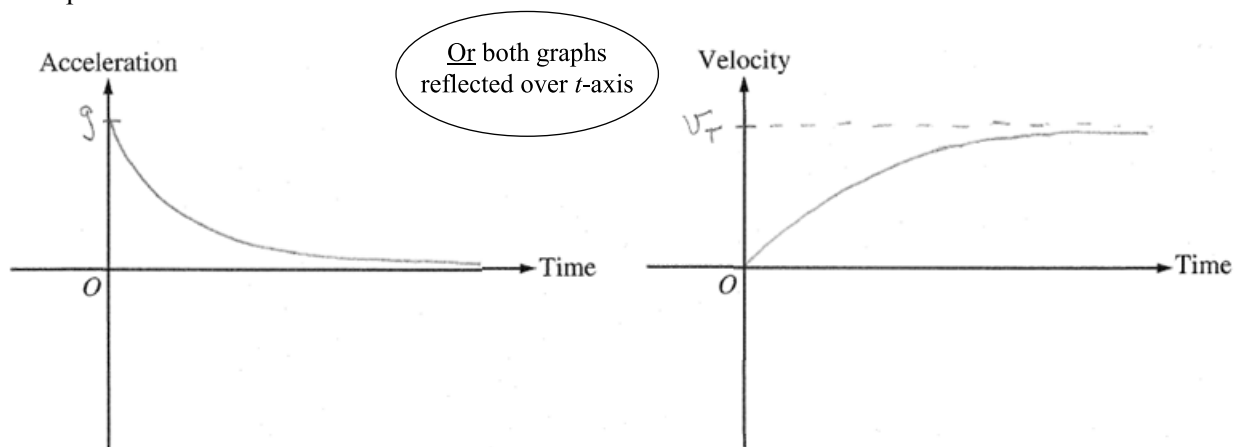

For an acceleration graph that does NOT begin at the origin

1 point

For an acceleration graph that has a horizontal asymptote of $a = 0$

1 point

For a velocity graph that begins at the origin

1 point

For a velocity graph that has a horizontal asymptote of $v = v_T$ or $-v_T$, as appropriate

1 point

For having both graphs with proper and accurate curvature

1 point

**AP[®] PHYSICS C: MECHANICS
2013 SCORING GUIDELINES**

Question 2

15 points total

**Distribution
of points**

(a) 4 points

For a correct statement of the conservation of momentum

1 point

$$p_i = p_f$$

$$m_1 v_{1i} + m_2 v_{2i} = m_1 v_{1f} + m_2 v_{2f}$$

For correctly substituting into the above equation

1 point

$$(0.30 \text{ kg})(2.0 \text{ m/s}) + (0.10 \text{ kg})(-3.0 \text{ m/s}) = (0.30 \text{ kg})v_{1f} + (0.10 \text{ kg})(1.2 \text{ m/s})$$

For a correct answer with units

1 point

$$v_{1f} = 0.60 \text{ m/s}$$

For correctly indicating the direction is to the right

1 point

(b) 2 points

For answering “no”, or that the collision is inelastic

1 point

For a correct justification

1 point

Examples:

No, the collision is not elastic. As shown in the calculations below, the final kinetic energy is less than the initial kinetic energy.

$$K_i = \frac{1}{2}(0.30 \text{ kg})(2.0 \text{ m/s})^2 + \frac{1}{2}(0.10 \text{ kg})(-3.0 \text{ m/s})^2 = 1.05 \text{ J}$$

$$K_f = \frac{1}{2}(0.30 \text{ kg})(0.60 \text{ m/s})^2 + \frac{1}{2}(0.10 \text{ kg})(1.2 \text{ m/s})^2 = 0.126 \text{ J}$$

No, the collision is not elastic. Since $v_{1f} < v_{1i}$ and $v_{2f} < v_{2i}$, K_f must be less than K_i .

No, the collision is not elastic. The final relative velocity is less than the initial relative velocity.

(c) 3 points

For a correct statement of the conservation of energy

1 point

$$K_1 = U_{S2} \quad \text{or} \quad \frac{1}{2}m_1 v_1^2 = U_{S2}$$

For correctly substituting into the above equation

1 point

$$U_{S2} = \frac{1}{2}(0.10 \text{ kg})(1.2 \text{ m/s})^2$$

For a correct answer with units

1 point

$$U_{S2} = 0.072 \text{ J}$$

Note: If the student uses the wrong cart, mixes up values for mass and/or velocity, or has a sign error, only the first point can be earned.

**AP[®] PHYSICS C: MECHANICS
2013 SCORING GUIDELINES**

Question 2 (continued)

**Distribution
of points**

(d) 3 points

For a correct expression for the potential energy of a spring

1 point

$$U = \frac{1}{2}kx^2$$

Substituting into the above equation

$$(0.072 \text{ J}) = \left(\frac{1}{2}\right)(k)(0.10 \text{ m})^2$$

For an answer consistent with part (c)

1 point

For correct units

1 point

$$k = 14.4 \text{ N/m (or kg/s}^2\text{)}$$

Note: There was no penalty for a sign error. If the wrong cart was used in part (c), then an acceptable answer is $k = 10.8 \text{ N/m}$.

(e) 3 points

For setting up a correct integral

1 point

$$U = -\int Fdx = \int bx^3dx$$

For a correct equation for the potential energy of the spring

1 point

$$U = \frac{1}{4}bx^4$$

Substituting into the above equation

$$(0.072) = \left(\frac{1}{4}\right)(b)(0.10 \text{ m})^4$$

For an answer consistent with part (c) and with correct sign and units

1 point

$$b = 2880 \text{ N/m}^3 \text{ [or kg/(m}^2\text{}\cdot\text{s}^2\text{)]}$$

Note: If the wrong cart was used in part (c), then an acceptable answer is

$$b = 2160 \text{ N/m}^3 .$$

**AP[®] PHYSICS C: MECHANICS
2013 SCORING GUIDELINES**

Question 3

15 points total

**Distribution
of points**

(a) 4 points

For correctly expressing the acceleration as the slope or rate of change of velocity

1 point

$$a = \text{slope} = \frac{\Delta v}{\Delta t}$$

For using two points from a best-fit line to calculate the slope/acceleration (not data points unless the data points are on the line)

1 point

$$a = \frac{(1.52 - 0.71) \text{ m/s}}{(0.55 - 0.25) \text{ s}}$$

For a reasonable numerical value for a

1 point

For correct units (was earned even if numerical answer was not correct)

1 point

$$a = 2.7 \text{ m/s}^2 \quad (\text{acceptable range of answers: } 2.5 \text{ to } 3.3)$$

(b) 5 points

For a correct expression of Newton's 2nd law for rotational motion

1 point

$$\tau = I\alpha$$

$$TR = I\alpha$$

For a correct substitution for the angular acceleration in terms of the linear acceleration

1 point

$$\alpha = a/R$$

$$TR = I(a/R)$$

$$I = \frac{TR^2}{a}$$

For a correct expression of Newton's 2nd law for translational motion

1 point

$$F_{\text{net}} = ma$$

$$mg - T = ma$$

$$T = m(g - a)$$

Substituting the expression for T into the expression for the rotational inertia

$$I = \frac{TR^2}{a} = \frac{m(g - a)R^2}{a}$$

Substituting values into the above equation

$$I = \frac{(0.05 \text{ kg})(9.8 \text{ m/s}^2 - 2.7 \text{ m/s}^2)(0.10 \text{ m})^2}{(2.7 \text{ m/s}^2)}$$

For a numerical answer consistent with part (a)

1 point

For correct units

1 point

$$I = 0.0013 \text{ kg}\cdot\text{m}^2 \quad (\text{the acceptable range for } a \text{ gives a range of } 0.000985 \text{ to } 0.00146, \\ \text{or using } g = 10 \text{ m/s}^2 \text{ a range of } 0.00101 \text{ to } 0.0015)$$

**AP[®] PHYSICS C: MECHANICS
2013 SCORING GUIDELINES**

Question 3 (continued)

		Distribution of points
(c)	4 points	
	For a correct expression for angular momentum	1 point
	$L = I\omega$	
	For correct substitution into any proper rotational kinematics expression	1 point
	$\omega = \alpha t$ and $\alpha = a/R$ or $\omega = v/R$ and $v = at$	
	$L = Iat/R$	
	Substituting into the above equation	
	$L = (0.0013 \text{ kg}\cdot\text{m}^2)(2.7 \text{ m/s}^2)(0.45 \text{ s})/(0.10 \text{ m})$	
	For a numerical answer consistent with part (a) and part (b)	1 point
	For correct units	1 point
	$L = 0.016 \text{ kg}\cdot\text{m}^2/\text{s}$	
	An alternate solution using $L = I\omega/R$ and using the graph to determine v at $t = 0.45 \text{ s}$ was also acceptable.	
(d)	2 points	
	For correctly selecting “Less than”	1 point
	For a correct justification	1 point
	Examples:	
	The same force is applied to the system (or the same torque acts on the hoop/disk). Rotational inertia is higher for a hoop than a disk, so the acceleration will decrease.	
	Since the potential energy stays the same and the rotational inertia of a hoop is greater than that of a disk, more of the energy goes into rotating the disk and less into moving the block. So the linear acceleration of the block will be less with the hoop than with a disk. Since $\alpha = a/R$, the angular acceleration of the hoop will be less.	
	A derivation of $a = \frac{mgR^2}{I + mR^2}$, $\alpha = \frac{mgR}{I + mR^2}$, or an equivalent expression, and an explanation that the rotational inertia of the hoop is larger.	

Scoring Worksheet

The following provides a worksheet and conversion table used for calculating a composite score of the exam.

2013 AP Physics C: Mechanics Scoring Worksheet

Section I: Multiple Choice

$$\frac{\text{Number Correct}}{\text{(out of 35)}} \times 1.2857 = \frac{\text{Weighted Section I Score}}{\text{(Do not round)}}$$

Section II: Free Response

$$\text{Question 1 } \frac{\text{_____}}{\text{(out of 15)}} \times 1.0000 = \frac{\text{_____}}{\text{(Do not round)}}$$

$$\text{Question 2 } \frac{\text{_____}}{\text{(out of 15)}} \times 1.0000 = \frac{\text{_____}}{\text{(Do not round)}}$$

$$\text{Question 3 } \frac{\text{_____}}{\text{(out of 15)}} \times 1.0000 = \frac{\text{_____}}{\text{(Do not round)}}$$

$$\text{Sum} = \frac{\text{_____}}{\text{Weighted Section II Score (Do not round)}}$$

Composite Score

$$\frac{\text{Weighted Section I Score}}{\text{_____}} + \frac{\text{Weighted Section II Score}}{\text{_____}} = \frac{\text{Composite Score (Round to nearest whole number)}}{\text{_____}}$$

AP Score Conversion Chart
Physics C: Mechanics

Composite Score Range	AP Score
63-90	5
51-62	4
40-50	3
29-39	2
0-28	1

AP Physics C: Mechanics

The College Board

The College Board is a mission-driven not-for-profit organization that connects students to college success and opportunity. Founded in 1900, the College Board was created to expand access to higher education. Today, the membership association is made up of over 6,000 of the world's leading educational institutions and is dedicated to promoting excellence and equity in education. Each year, the College Board helps more than seven million students prepare for a successful transition to college through programs and services in college readiness and college success — including the SAT[®] and the Advanced Placement Program[®]. The organization also serves the education community through research and advocacy on behalf of students, educators, and schools. The College Board is committed to the principles of excellence and equity, and that commitment is embodied in all of its programs, services, activities, and concerns.

Visit the College Board on the Web: www.collegeboard.org.